

Table of Contents

Principal's Message.....	1
Philosophy - Vision.....	2
PTO - School Councils.....	3
School Calendar	4
Student Records.....	4
Parent-Teacher Conferences.....	4
School Pictures.....	4
Lost and Found.....	4
Student Drop-off and Pick-up.....	5
Safety and Transportation.....	7
School Cancellation/Delayed Openings.....	8
School Visitations.....	8
Student Absences/Early Dismissal.....	8
School Lunches.....	9
Pupil Conduct.....	9
Homework Policy.....	11
Progress Reporting.....	11
Insurance/Student Information.....	11
Special Services.....	12
Health Policies.....	12
Code of Conduct reference.....	14
Professional Staff.....	15

PRINCIPAL'S MESSAGE

Dear Mapleshade Students and Parents,

Another school year is about to begin! While the summer kept tricking us with the weather, it did provide time to relax, renew, and recharge. I hope that this is true for all of you! It is great to be back and have the opportunity to welcome you all to Mapleshade School. The Staff joins me in these wishes. We have a terrific family here and we are happy that you will be part of it. I look forward to a fabulous year working together!

This handbook is filled with important information and I hope you find it useful. I encourage parents and students to read the Handbook together, talk about the various information, and, feel free to call us or ask a staff member if you need an explanation or clarification. We have entered some additional information. It should not take very long to read and it gives everyone a better view of the pulse of our school. When there is an understanding of the expectations, the year will go smoothly and our children will feel happy and safe.

Lastly, please become part of our Mapleshade family. Let us work together to create a vibrant, exciting, and respectful place, a place where people like to come, where there are a variety of activities for all of us, and, above all, a welcoming atmosphere.

Welcome back!!

Brenda S. Houle

PHILOSOPHY - VISION

PHILOSOPHY

The purpose of our statement of educational philosophy is to articulate clearly the overall beliefs of our school system and school to the community. The school system has two roles: 1) to reflect the values and to respond to the needs and desires of the community and 2) to challenge the students to greater accomplishments and aspirations.

A basic underlying theme of our educational system is that everyone (students, staff and community) can learn from one another. The understanding of and the respect for the diversity of ethnic, cultural, intellectual and physical differences permeate all aspects of the school system.

Professional staff recognizes and respond to the intellectual capacity and learning style of each individual student. Individuals grow intellectually at different rates and in different ways. A complete education exposes all students to a wide range of learning opportunities.

Learning is viewed as the primary focus of each student's experience. Students are provided opportunities to continually develop their intellectual, physical, social and emotional potential. It is recognized that the student's self-esteem is of paramount importance in this process. Opportunities for development are nurtured in all learning situations. In order to maximize the attainment of these goals, student-centered experiences are provided by all staff.

In keeping with the desire to place the student at the center of learning, the teacher will be viewed as facilitator and coach. All staff will establish an appropriate learning environment and provide feedback to allow each student the opportunity to master appropriate academic, social and emotional skills for which the student is ready.

Mapleshade is committed to educational excellence. Teachers are at the center of this process and are supported in their efforts to provide their students with a quality education.

VISION

The purpose of an educational vision is to provide direction to the school system. As educators, we believe that it is our responsibility to prepare the youth of our community for an increasingly complex society. In order to fulfill that responsibility, we place the student at the center of the learning process. It is important that the educator's role become one of facilitator and coach.

In keeping with this mission, we provide our educators with the following guidelines to serve as the template for the learning environment.

- A. Learning occurs when teacher's expectations are that all students can be successful and that all students can learn.
- B. Learning is best facilitated by instructors who have a command of content knowledge as well as awareness of the individual student's abilities and learning style.
- C. Learning is characterized by active, engaged, collaborative and integrated exploration with the student at the center of all activities.
- D. Learning optimally occurs through interactive and cooperative experiences among teachers, students, parents and the community.
- E. Learning reflects a focus on thinking, reasoning and higher order questioning as well as the understanding of the learner's own thinking processes.
- F. Learning is driven by a search for meaningful answers or alternative solutions to problems. Learning is maximized when the student's work is thought-provoking and when content is viewed as a means to a larger end.

PTO

The Mapleshade PTO is dedicated to enriching the educational experience of every child at Mapleshade School through a variety of activities. All parents are automatically members and are invited to actively join in. Yearly fundraisers allow the PTO to fund enrichment programs, field trips and to purchase school equipment. The PTO also runs annual book fairs, a Jog-A-Long, a Family Night, a Holiday Shop and a Teacher Appreciation Week. Our scheduled meetings keep parents informed of school and system related matters. Remember, we are working for our children. Your ideas are welcomed and your participation is appreciated.

SCHOOL COUNCILS (Chapter 71, Section 59C:)

At each public elementary school in the Commonwealth there shall be a school council consisting of the school principal, who shall co-chair the council; parents of students attending the school, who shall be selected by the parents of students attending such school, who will be chosen in elections held by the local recognized Parent Teacher Organization under the direction of the principal. Said parents shall have parity with professional personnel on the school councils; teachers who shall be selected by the teachers in such school; other persons, not parents or teachers of students at the school, drawn from such groups or entities as municipal government, business and labor organizations, institutions of higher education, human services, agencies or other interested groups, however, that not more than fifty percent of the council shall be non-school members. The principal shall have the responsibility of defining the composition of and forming the group. School councils should be broadly representative of the racial and ethnic diversity of the school building and community.

The school council shall meet regularly with the principal of the school and shall assist in the identification of the educational needs of the students attending the school, in the review of the annual school budget and in the formation of a school improvement plan.

SCHOOL HOURS & CALENDAR

Opening Bell	8:10 A.M.
School in session	8:15 A.M.
First lunch	12:00 P.M.
Second lunch	12:30 P.M.
School day ends	2:30 P.M.

The School Calendar, which is sent home with your child at the beginning of the school year, contains information such as dates of marking periods, distribution of report cards, parent conferences and curriculum days, vacation periods, school hours, etc. By making reference to the calendar many answers to school related questions may be quickly obtained.

STUDENT RECORDS

Federal Regulations and the Commonwealth of Massachusetts Board of Education Regulations require that all records pertaining to an individual student be made available for inspection by the parents. If you wish to review your child's records, please contact the school for information regarding the procedure to be followed.

PARENT-TEACHER CONFERENCES

Parent-Teacher conferences are regularly scheduled during the year as noted on the school calendar. Parents will receive notification of their specific conference dates and times. Parents are encouraged to call the school at any time and ask about their child's progress. A partnership between parents and teachers results in benefits for the child.

SCHOOL PICTURES

School pictures are annually taken in the Fall. Although every child is photographed, this does not obligate the parents or guardian in any way to make a purchase.

LOST AND FOUND

Articles which have been found in the building or on school grounds are turned in to the office, where they may be claimed by their owners. It is suggested that articles of clothing, lunch boxes

and other personal items be labeled with the child's name. This enables us to return lost items to the rightful owner. Losses should be reported and the "Lost and Found" box should be checked periodically whenever losses occur. At midyear, and again at the end of the year, unclaimed clothing is donated to a local shelter.

STUDENT DROP-OFF AND PICK-UP

IMPORTANT NOTE: The main parking lot and fire lane (yellow curbing area) are reserved for busses from 8:00 a.m. to 8:30 a.m. and from 2:00 p.m. to 2:30 p.m. Cars should not enter this area during these times. If a parent needs to drop off or pick up a child between the hours of 8:30 a.m. and 2:25 p.m., they should park their car in the parking lot and escort the child to or from the building. No drop-offs prior to 8:00 a.m. as there is no supervision.

Parents dropping off students before school and picking up students at the end of the school day should use the new drive-thru road. The purpose of the drive-thru is to provide safer conditions for students traveling to and from school by car. However, the safety of each child still depends upon the patience and caution of adults using the drive-thru. Town officials have given considerable time and thought in planning the traffic flow of the drive-thru. There are ample signs and pavement markings clearly indicating how vehicles should proceed through the drive-thru area. There will be staff on duty to assist parents and students in learning the proper procedures. If we all work together, we will improve student safety at Mapleshade.

The following are important guidelines for the use of the drive-thru (refer to the accompanying diagram):

- The drive-thru is designed for ONE-WAY TRAFFIC ONLY. Traffic should flow only from WEST to EAST. All traffic will enter at the point designated "A" on the diagram. This is the end furthest from the school.
- Cars must proceed slowly at all times.
- Cars are not to park on the yellow hashmarks (marked as "B" on the diagram). These hashmarks are found at the beginning and the end of the drive-thru. Students may be dropped at any point along sidewalk side of carline.
- Cars coming into the drive-thru should pull up as far as possible and to the right of the white line indicating the drop-off/pick-up zone. Once the student passengers have been dropped off or picked up, the driver should pull out to the left into the thru-traffic lane. Drivers must be alert to other drivers pulling out and to those already in the thru-traffic lane. It is critical that no one park beyond the point designated "C" on the diagram. The drive-thru narrows near the exit and cars parked beyond "C" will block other cars from exiting.

- Note: The drive-thru area is NOT A PARKING LOT. Drivers must not leave their cars.

**Please be aware that teacher supervision before school does not begin until 8:00 a.m.
Therefore, no student should be dropped off before 8:00 a.m.**

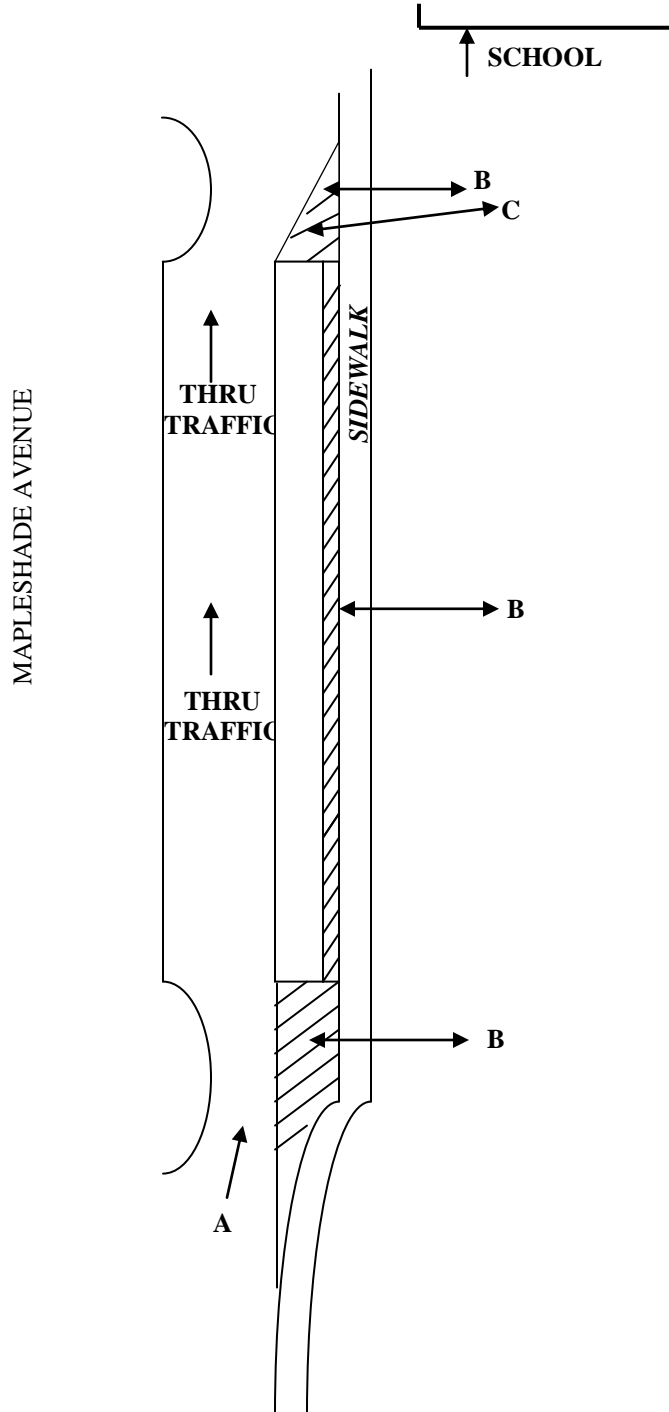

SAFETY AND TRANSPORTATION

Alerting children to the need for being “safety conscious” at all times is a never-ending responsibility. Children should learn the need for rules and recognize the importance of obeying them. The following are safety guidelines to be shared with your child.

A. Walking

1. Walk on sidewalks (no more than two abreast), when they are available.
2. Walk on the left side of the road if there are no sidewalks.
3. Walk in an orderly manner, keeping alert to any dangers. **Do not stop for strangers.**
4. Come directly to school and go directly home.
5. Look in all directions before crossing any street.
6. Cross streets at proper corners.
7. Respect all public and private property.
8. When possible, children should walk home in groups of at least 2 children.

B. Bicycling

1. Use a bicycle helmet and hand signals. This is the law.
2. Never ride two on a bicycle.
3. Keep bicycle under control and in good repair at all times.
4. Look in all directions before crossing a street.
5. Ride your bicycle on the right-hand side of the street.
6. Be careful of walkers and especially automobiles.

C. Bussing

1. Stay out of the street while waiting for the bus.
2. Refrain from pushing or otherwise endangering yourself and friends while waiting at the bus stop.
3. Wait until the bus comes to a full stop before going near it.
4. Take a seat in the bus and remain orderly while the bus is in motion.
5. Keep head, arms and hands inside the bus window.
6. No food or gum of any kind is allowed.

The school authorities, the bus operators and the police work closely to insure safe operations of all busses. Parental cooperation plays a large part in the success of this phase of the school program. If a pupil's actions are dangerous to himself or the safety of others, the privilege of riding a bus will be withdrawn.

At present, a system of bus warning slips is in operation. When a ticket is issued by a bus driver, it is to be signed by the parent or guardian and then returned to the school office for disposition.

Bus pupils are assigned to a specific bus. Children may not ride a bus other than the one to which they are assigned.

Crossing in front of busses is permitted by State Law. Extreme care must be exercised in crossing. Look both ways and then cross when no vehicles are moving. The East Longmeadow Public Schools specific "Rules of Conduct" on busses will be handed out to each student rider at the beginning of the school year.

SCHOOL CANCELLATIONS OR DELAYED OPENING

It is the policy of the East Longmeadow Public Schools to remain open whenever the buildings are in operating order and the busses can run. In doubtful cases, the final decision whether or not school will be in session is not made until 6:30 a.m. If the decision is to cancel school or delay the starting time, then the local radio stations will carry a "No School" or "Delayed Starting Time" announcement. An automated phone message will also notify families.

SCHOOL VISITATIONS

In the interest of maintaining good building security, all visitors are requested to stop at the school office upon entering the building. Visitors are also urged to use the designated parking areas and to be conscious of keeping bus loading areas and fire lanes clear of automobiles.

STUDENT ABSENCES

It is the desire of our schools to encourage good school attendance. We also realize that from time to time students are absent for various reasons. Parents may call in to report absences. It is always helpful to your child's teacher if a note accompanies your child on his/her return to school following any absence. An automated phone message is sent to confirm absence.

EARLY DISMISSAL

Pupils who are to be dismissed before the end of the school day should bring a written request signed by a parent/guardian. The written request is given to the homeroom teacher and sent to

the office. Only in case of illness or emergency will dismissals be granted during the day without a note from home. Students will be dismissed from the school office to the parent, guardian or an individual designated by the parent.

SCHOOL LUNCHESES

A well-balanced lunch is available at nominal cost. The menus for each month are distributed by the schools and also published in local newspapers. Milk may be purchased by those who bring their own lunches. Lunch and milk are paid for on a daily basis.

We understand that students occasionally forget to bring their cold lunch or hot lunch money to school. We have set up a system where our students may borrow funds for lunch. (Loans are not made for the purchase of ice cream).

As our petty cash box has a limited amount of money, we would appreciate repayment of the lunch loan the following school day. Should any student forget to pay back the loan within **two days**, a reminder will be issued. Should that notice go unanswered, a phone call may be made to inform the parents or guardians of the outstanding debt.

If you wish to purchase tickets in advance, you may do one of the following:

1. Mail a check payable to the East Longmeadow School Department along with an enclosed self-addressed stamped envelope to: School Lunch Department, 180 Maple Street, East Longmeadow, MA 01028
2. Buy tickets at Mapleshade Elementary School in the cafeteria daily from 10:30 to 11:35 a.m.
or
3. Buy tickets at the High School lunch office daily from 8:30 a.m. to 2:30 p.m.

PUPIL CONDUCT

Establishing and maintaining standards of good conduct for young people are responsibilities mutually shared by the home and school system. Conduct that reflects self-respect and a concern for others is a desirable lifetime goal.

The East Longmeadow Public School's Character Committee has determined that the following character traits should be promoted in all of the activities of the East Longmeadow Public Schools: Kindness, Perseverance, Respect, Responsibility, Caring, Courage, Empathy, Honesty, and Inclusive.

A. Behavior on school grounds

1. Proper playground behavior is SAFE, FAIR PLAY, no pushing, shoving, kicking, tackling or fighting is allowed.
2. Equipment is to be shared fairly among students.
3. All snacks will be eaten on the blacktop area.
4. There should be no sharing of snacks because of allergy concerns.
5. Weather conditions will determine the types of activities available.

B. Behavior during indoor recess

1. Games will be appropriate for indoors.
2. Indoor voices should be used.
3. Students will remain in their homeroom.

C. Building and Classroom behavior

1. Disrespect and/or willful disobedience to a teacher, administrator, or other persons in authority are prohibited.
2. Students will be held responsible for the willful destruction of school property and the personal property of others.
3. The use of offensive language and gestures is prohibited.
4. Fighting and behavior that is threatening to oneself or to the safety of others is prohibited.
5. Smoking is prohibited on school grounds or in the school building.
6. Students will respect everyone's RIGHT TO LEARN and not distract others students in any way.
7. Students will not bring unsafe items to school.
8. Students will walk while inside the school building.
9. Possession of alcoholic beverages, drugs or weapons is prohibited.

D. Behavior in the lunchroom - students will:

1. Observe good table manners
2. Stay seated while eating.
3. Use indoor voice.
4. Not throw food or trash on the floor.
5. Wait to be excused to empty trash and trays.
6. Follow the instructions of the lunchroom supervisors at all times.
7. Not go back to the classroom or to the bathroom without adult permission.
8. When dismissed, walk to the playground for recess.
9. No lending or borrowing of money for lunch purposes.

E. Care of textbooks and other school property

1. Damaged and/or lost books are to be paid for by the student or parent.
2. Damages to the building, equipment, and other school property becomes the responsibility of the offending student or parent.

HOMEWORK POLICY

Regular homework is assigned each Monday through Thursday. Grade 3 will have approximately 30 minutes, Grade 4 will have approximately 35 minutes and Grade 5 will have approximately 40 minutes. At times, in addition to regular homework, projects, book reports and study time will also be assigned. Assignments are recorded in students' assignment books and should be acknowledged by a parent each night.

The purpose of this policy is to develop good home study habits. We suggest that the student have a quiet study place away from the family activity. It is encouraging when the parents become involved in the homework program and check over the assignment to see that it is completed and ready on time. Refer to Code of Conduct for details.

Students who forget homework materials will not be allowed back in the building to get their work after 3:30 p.m.

PROGRESS REPORTING

Report cards are issued on a regularly scheduled basis as indicated on the School Calendar. The report card should be signed by a parent or guardian and returned to the student's teacher.

INSURANCE

A student accident policy is available to all children. Application forms must be signed and returned to the teacher whether they are taking the insurance or not.

STUDENT INFORMATION

The school is allowed to release for publication certain information concerning your child without first obtaining your consent. Examples of the type of information released would be the student's name, class participation in officially recognized activities, and honors and awards.

If a parent does not wish that certain or all of this information be released for publication, the office of the school principal must be contacted so they may obtain a form that would restrict the school from releasing such information.

SPECIAL SERVICES

Special programs are available for elementary school children who have specific learning and emotional problems standing in the way of learning. Careful evaluations are made by members of the Guidance and Special Services' team to better serve the special needs of the children. Specialists in counseling, speech, reading and special education are involved in the program.

All students are expected to meet the requirements for behavior as set forth in this handbook. Chapter 71B of the Massachusetts General Laws, known as Chapter 766, requires that additional provisions be made for students who have been found by an evaluation TEAM to have special needs and whose program is described in an Individual Educational Plan (IEP).

The following requirements apply to the discipline of special needs students:

1. The IEP will indicate whether the student can be expected to meet the regular discipline code. Any modification of the rules set forth in this handbook will be described in the IEP.
2. The Principal or Head Teacher will notify the Special Education Department Chairman of the suspendable offense of a special needs students and a record will be kept of such notices.
3. When it is known that the suspension of a special needs student will accumulate to ten days in a school year, a review of the IEP as provided in Section 333 of the Chapter 766 Regulations will be held to determine the appropriateness of the student's placement or program. The TEAM will make a finding as to the relationship between the student's misconduct and his/her handicapping condition and either; (a) design a modified program for the student or (b) write an amendment to provide for the delivery of special education services during the suspension and any needed modification of the IEP relative to discipline code expectations.

HEALTH POLICIES

Every effort is made to care for your child's physical, mental and emotional well-being. Sick and injured children are given emergency care but the responsibility for treatment rests with the family.

An "Emergency Information Form" will be sent home to the parents. This form requests information as to the address and place of employment of the parents, the address and telephone number of at least two relatives or close friends who would be willing to care for your child if you are unavailable. It also requests your permission to secure medical attention for your child in case we can't reach you.

Illness and First Aid

Pupils should not come to school when they are ill. Injuries, skin irritations, etc., which arise outside of school, should be cared for at home or through the family doctor. School related accidents and injuries must be reported to the teacher in charge who will then report them to the school office.

Administration of Prescribed Medication

The policy for prescribed medication and the forms which must be filled out by parents or guardians and the physician are available from the school nurse.

Every attempt should be made so that medication is given when the child is not in school. We will cooperate in the administration of medication when a chronic or emergency condition exists and medication must be administered in school. To administer medication, the following conditions must be met:

1. There must be on file in the school a written order from the pupil's physician.
2. The pupil's parents and or guardians must submit a completed pertinent data sheet asking that the pupil receive the medication during school hours.
3. The required medication must be kept in a locked cabinet in the school health room and be given by the school nurse or a person designated by the school nurse.
4. The medication shall be issued by a pharmacist whose label on the container shall indicate:
 - a) the name of the child and the prescribing physician.
 - b) the name and strength of the medication.
 - c) the amount of each dose and schedule for administration of the medication.

**PLEASE SEE THE ENTIRE CODE OF CONDUCT
Rules of Conduct AND ACCEPTABLE INTERNET USE POLICY
contained in the E.L.P.S. CODE OF CONDUCT
in addition to this handbook.**

**You must sign that you have read the E.L.P.S. Code of Conduct
and discussed it with you child.**

Thank you for your cooperation in keeping the children of East Longmeadow safe. Working together we will provide a safe, high-quality learning environment for all of our children.

2009-2010 MAPLESHADE STAFF

Principal – Brenda Houle

Secretary – Elaine Lucci

Nurse – Nancy Paulides

Grade 3

Room 1 – Andrea Brewster-Gray

Room 2 – Mary Toller

Room 3 – Marianne McCauley

Room 4 – Ann Marie Jagodowski

Room 5 – Bruce Goldman

Gr. 3 Paraprofessionals:

Cathy DeBonville

Suzanne Pate

Carol Walder

Grade 4

Room 12 – Christianne McCandlish

Room 13 – Lorraine Malone

Room 14 – John Wiedersheim

Room 15 – Bill Sears

Room 16 – Susan Kingston

Gr. 4 Paraprofessionals:

Patti Frogameni

Beth LaFountain

Grade 5

Room 9 – Amy Simmons

Room 10 – Marie Matulewicz

Room 18 – Ryan McMullen

Room 19 – Jeff Bohonowicz

Room 20 – Joanne Grimes

Gr. 5 Paraprofessionals:

Paula Garvey

Fran Mercieri

Holly Normoyle

Donna Rinaldi

Room 6 – Learning Center: Mary Ellen Keiter; Paraprofessionals: Diane Elkhay; TBA

Room 7 – Special Education: Gr. 3 – Beth Pardo; Gr. 4 – Joanne Brown; Gr. 5 – Angela Abair
Paraprofessional: Nora Cuch

Room 8 – Art: Therese Moriarty

Room 8 – Music (Vocal): Veronica Richter

Library: Deb Foley

Library Media Specialist: Barbara Schofield

Room 11: Computer Lab

Room 17 – Speech: Amy Jones

Room 17 – Reading: Deb Douville; Paraprofessionals: Laura D’Angelo, Kathy LaPorte, Emilie Nesbitt, Nancy Stannard, Caroline Young

Room 21 – Gifted and Talented: Deb Barry

Room 22 – Guidance: Dale Carey

Room 23 – Psychologist: Cheri Minehan

Room 24 –Physical Education: Diana Demetrius

Stage – OT: Charlotte McIntyre

PT: Sue Zuraw

Band: Amy Grossi

Lunch Room: Ro Gelinas, Andrea Pappelardo

Noon Aides: Laura D’Angelo, Kathy LaPorte, Emilie Nesbitt, Caroline Young

Head Custodian: Michael Scully **Night Custodian:** Ray Cauley **Bathrooms:** Ralph Buddington